

Instruction Manual

HI 8410

Dissolved Oxygen Process Controller

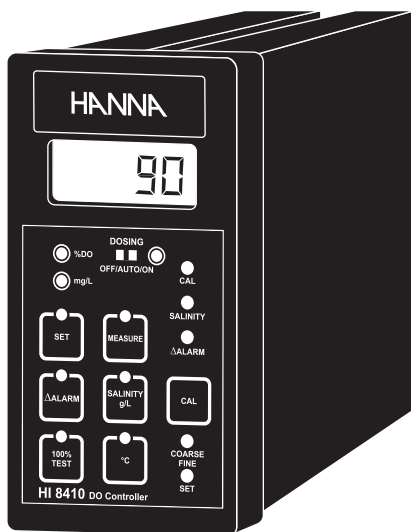

w w w . h a n n a i n s t . c o m

Dear Customer,
Thank you for choosing a HANNA instruments® product.
Please read this instruction manual carefully before using the instrument.
This manual will provide you with all the necessary information for correct use of the instruments, as well as a precise idea of their versatility in a wide range of applications.
If you need additional technical information, do not hesitate to e-mail us at tech@hannainst.com.

TABLE OF CONTENTS

Preliminary Examination	3
General Description	3
Functional Description HI 8410	4
DO Probes	8
Specifications HI 8410	9
Connections	10
Operational Guide	12
Taking Measurements with HI 8410	15
Calibration Procedure	16
Diagnostic Tests	16
LED Indication	17
Probe Maintenance & Cleaning	18
Accessories	18
Warranty	19

PRELIMINARY EXAMINATION

Remove the instrument from the packing material and examine it carefully to make sure that no damage has occurred during shipping. If there is any damage, notify your dealer.

The meter is supplied complete with

- Mounting brackets
- Transport splash-proof cover
- Instructions manual.

Note: Conserve all packing material until the instrument has been observed to function correctly. Any defective item must be returned in its original packing.

GENERAL DESCRIPTION

HI 8410 is a panel-mounted DO controller designed for simplicity of use in a wide range of industrial process applications.

Dissolved Oxygen is indicated in mg/L (ppm) or in % of saturation in accordance with the selection switch on the back panel. The temperature can be measured in the range from -5 to 50 °C. The Dissolved Oxygen readings are automatically compensated for the temperature effects on the oxygen solubility and membrane permeability. Moreover, the salinity compensation feature allows the determination of Dissolved Oxygen even in salty waters.

The instruments are designed with a standard DIN panel mount with membrane keypads and large LCD with backlight on the front, and provide a series of auto-diagnostic functions.

Probes, power supply, contacts and recorders are connected on the rear panel through screw terminals.

For control applications use the **HI 76409/4** or **HI 76409/10** galvanic probes.

The DO probe is provided with a membrane covering the galvanic sensor and a built-in thermistor for temperature measurement and compensation. The Oxygen that passes through the membrane causes an electric current flow, from which the oxygen concentration is determined.

Other features include: recorder output in 0-20 mA or 4-20 mA configuration; LED indicators which identify whether the controller is in operation mode or setup selection mode; overtime control function; hysteresis setting.

The instrument is supplied with a plastic front cover and two mounting brackets. Power cables are not included.

Note: In order to avoid erroneous readings never use both 0-20 mA and 4-20 mA recorder outputs at the same time.

FUNCTIONAL DESCRIPTION HI 8410

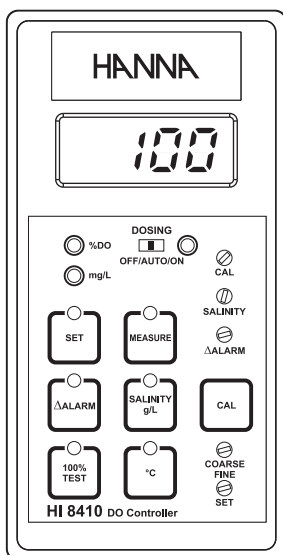

KEYPAD

MEASURE

To read measurements and enable diagnostic tests

ΔALARM

To display and set the tolerance of the alarm

SET

To display and set the working dosing point

SALINITY g/L

To display and set the salinity factor (active only in mg/L range)

CAL

To enter in calibration mode

100% TEST

Diagnostic function (active only in % DO range)

°C

To display the temperature reading

When a key is pressed, the corresponding LED lights up to indicate that the function is active.

TRIMMERS

CAL

For 100% DO calibration

SALINITY

To set the salinity concentration (g/L)

ΔALARM

To set the alarm tolerance

SET COARSE

To coarsely adjust the set point

SET FINE

To finely adjust the set point

LEDS

% DO	To indicate that the DO is displayed in % of saturation
mg/L	To indicate that the DO is displayed in mg/L
SET	To indicate that the dosage is active
△ALARM	To indicate an alarm condition
DOSAGE MODE SWITCH	To indicate that the continuous ON or OFF mode is selected from dosing switch

SWITCHES

OFF/AUTO/ON	To select the dosing mode: <ul style="list-style-type: none">• OFF - dosing is disabled• AUTO - automatic dosage, depending on setpoint and reading values• ON - dosing always active
--------------------	--

REAR PANEL OF HI 8410

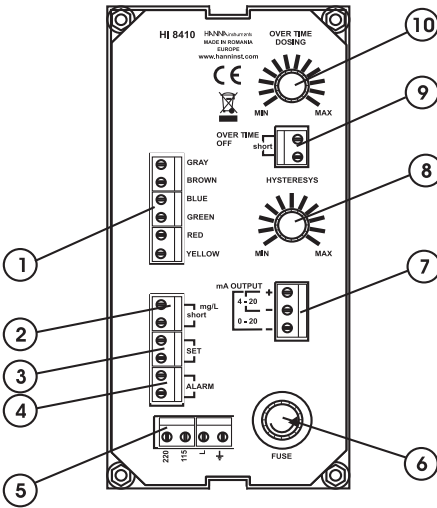

1. DO probe connection terminals
2. Range selection: mg/L or % DO
3. SET terminals for connection to a dosing pump
4. ALARM terminals for connection to an external alarm device
5. Power supply terminals
6. Fuse holder
7. mA OUTPUT terminals for connection to a recorder
8. Hysteresis set knob (0.5 to 2.4 mg/L)
9. Disable overtime dosing connection
10. Overtime dosing set knob (about 5 to 60 min)



Unplug the instrument from power supply before replacing the fuse.
Only one of recorder output connections (0-20 mA or 4-20 mA) can be used at a moment. Leave unconnected the unused terminal.

MECHANICAL DIMENSIONS
OF HI 8410

Front view of the panel-mounted unit

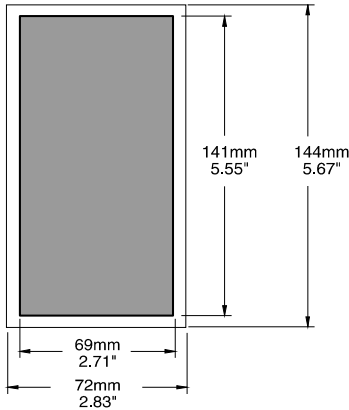

These dimensions show the cutout size for the installation.

Side view of the panel-mounted unit

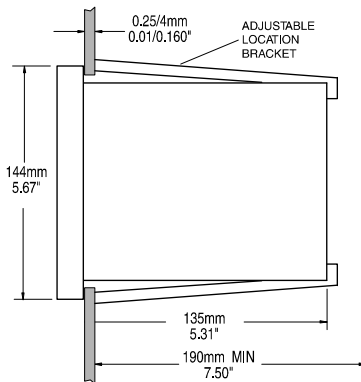

Adjustable location brackets (supplied with the meter) allow the indicator to slide into the cutout and will hold the unit securely in place. 190 mm (7.50") is the minimum amount of room required to install the indicator with the cables connected.

D.O. PROBES

All Hanna DO probes are shipped dry. To hydrate the probe and prepare it for use proceed as follows:

1. Remove the black & red plastic cap. This cap is used for shipping purposes only and can be thrown away.
2. Insert the supplied O-ring in the membrane (see figure).

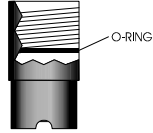

3. Rinse the supplied membrane (**HI 76409A/P**) with electrolyte while shaking it gently. Refill with clean electrolyte. Gently tap the membrane over a surface to ensure that no air bubbles remain trapped. To avoid damaging the membrane, do not touch it with your fingers.

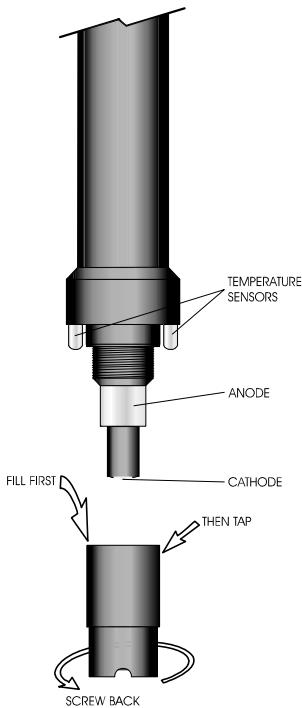

4. With the sensor facing down screw the cap clockwise to the end of the threads. Some electrolyte will overflow.

SPECIFICATIONS HI 8410

Range	0.0 to 50.0 mg/L (ppm) O ₂ 0 to 600 % O ₂ -5.0 to 50.0 °C
Resolution	0.1 mg/L or 1% (O ₂) / 0.1 °C
Accuracy	±1% of reading (O ₂) ±0.2 °C excluding probe error
Calibration	Manual, one point, in saturated air
Temp. Compensation	Automatic, from -5 to 50 °C (23 to 122 °F)
Salinity Compensation	0 to 51 g/L (resolution 1 g/L)
Probe (not included)	HI76409/4 HI76409/10
Recorder Output	0 to 20 mA or 4 to 20 mA (isolated)
Setpoint Relay and Alarm Relay	1, isolated, 2A, Max. 240V, resistive load, 1,000,000 strokes
Setpoint Range	5 to 600 % O ₂ 0.5 to 50.0 mg/L (ppm) O ₂
Alarm Range	0.5 to 5.0 mg/L (ppm) O ₂
Hysteresis Range	0.5 to 2.4 mg/L (ppm) O ₂
Dosing Control	OFF/AUTO/ON with selection switch
Over Dosing Control	Adjustable, from 5 min to 60 min with knob or Disable by wire strap - on real panel
Backlight	Continuous ON
Power Supply	115 or 230 Vac; ± 10% (user selectable); 60/50 Hz
Enclosure	Black anodized aluminum body; front and back with ABS; transparent splash-proof front cover
Environment	-10 to 50 °C (14 to 122 °F); RH 95%
Panel Cutout	141 x 69 mm (5.6 x 2.7")
Weight	1 kg (2.2 lb.)

CONNECTIONS

REAR CONNECTIONS FOR HI 8410

- **Power Connection Terminals**

4-screw-terminal-strip for connection to a 3-wire power cable according to the indicated voltage (115 or 230V).

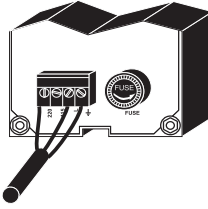

- **Probe Connection**

For connection of the **HI76409** DO probe. Connect the wires according with the indicated color.

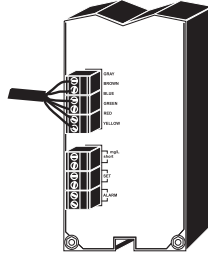

- **Range Selection**

To select mg/L range make a short with a jumper wire between the terminals (1, 2). To select % DO range leave terminals 1, 2 unconnected.

- **Set Contacts**

Dosing pumps or other control equipment may be connected to the "SET" (Max. 2A, 240 V) terminals (3, 4). These contacts act only as a "dry" switch allowing electrical continuity, not as a power supply.

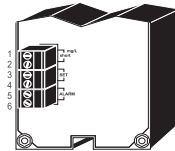

- **Alarm Contacts** (terminals 5, 6)

During normal operation these terminals remain closed.

If the measured DO level is not within the tolerance of the set value, the alarm contact is open. These contacts act only as a switch. See also page 15.

- **Recorder Output** (terminals 1, 2, 3)

These contacts are used for connection to a recorder output. The output can be 0-20 mA or 4-20 mA and is proportional to the measured Dissolved Oxygen values.

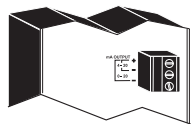

Connect the “+” wire from the recorder to terminal 1 on the instrument and the other wire (common) to terminal 2 for 4-20 mA recorder output or terminal 3 for 0-20 mA recorder output.

Note: Only one recorder output connection is permitted. In order to avoid malfunction leave unconnected the unused terminal.

- **Overtime dosing**

When enabled this feature ensures that overdosage is avoided. Select a desired maximum dosage period. If the dosage relay is active more than the selected period an alarm condition is activated and the dosage relay is deactivated.

To leave the overtime dosage alarm status change the position of the **OFF/AUTO/ON** switch to OFF and then to AUTO again. The overtime counter is restarted.

To set the overtime dosing period rotate the overtime knob to the proper position. The time can be set between approx. 5 min to 60 min (from MIN to MAX position).

To disable the overtime dosage feature make a short with a jumper wire between the terminals of the proper connectors. (see picture, terminals 1, 2)

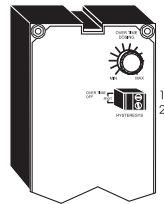

- **Hysteresis knob**

Put the hysteresis knob in the desired position. The dosage will be active according to the DO reading, set point value and the hysteresis set value.

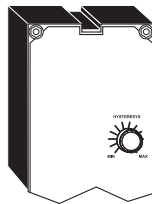

DOSING MODE SELECTION

The DOSAGE switch and the corresponding right side LED on the front panel are used to select and indicate the dosing mode.

OFF mode

The dosage is disabled. The corresponding DOSAGE MODE LED blinks (right side of the switch).

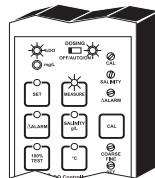

AUTO mode

The dosage is activated and deactivated according with the selected setpoint. The corresponding DOSAGE MODE LED is off. Be sure that the DOSAGE switch is in AUTO position when the meter is in normal operating mode.

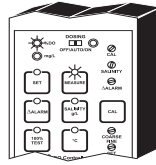

ON mode

The dosage is always activated. The corresponding DOSAGE MODE LED blinks.

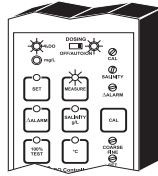

OPERATIONAL GUIDE

INITIAL PREPARATION & INSTALLATION

Material needed:

- a 3-wire power cable to connect **HI 8410**

Ensure the controller has been calibrated. Ensure the DO probe is immersed in the sample to be tested.

The DO reading can be displayed in % air saturation or in ppm (mg/L) according to the range selection. The corresponding LED is ON.

For accurate dissolved oxygen measurements a water flow of at least 5-7 cm/sec is required. In this way a constant replenishment of the oxygen-depleted membrane surface is ensured.

Accurate readings are not possible in still water.

Note: For some particular applications, such as fish farming, the membrane can be sterilized with stabilized iodine (20 to 50 ppm), typically used for this purpose.

Note: For use in harsh environments, it is recommended to protect the membrane with the optional **HI 76409-0** sleeve. The response time will slightly slow down.

Ensure that the **HI 76409** DO probe is connected to the meter according with the colors indicated on the mask.

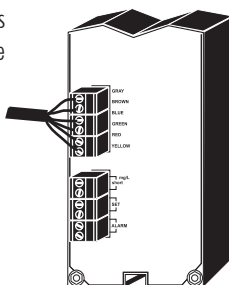

OPERATING INFORMATION

All parameters are set through the front panel keys and trimmers.

When any key is pressed, the corresponding LED lights up to indicate that the function is active.

SET POINT

To set the working point of the controller, press the SET key. The display will indicate the current set value.

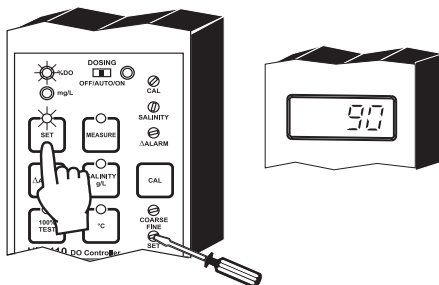

Use a small screwdriver to adjust the COARSE and FINE trimmers until the desired value is displayed in units according with the range selected (the corresponding % DO or mg/L LED is ON).

The dosing will be active when the DO reading is lower than the set point (set point + hysteresis overpassed = stop dosing; set point = start dosing).

SALINITY g/L SET (mg/L range only)

Oxygen measurements can be compensated for salinity concentration and this correction value can be set by the user.

Select the mg/L mode by using the corresponding switch (rear panel).

Press the SALINITY g/L and the display will show the salinity. Use a small screw driver to adjust the SALINITY trimmer to display the desired salinity value (within the 0 to 51 g/L range).

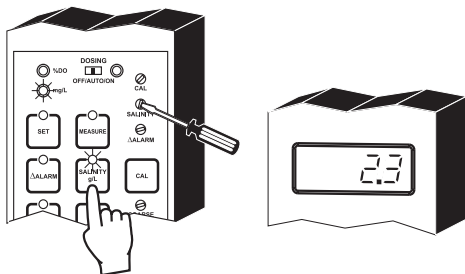

ALTITUDE COMPENSATION (mg/L range only)

When salinity compensation is not required (i.e. not salty water), the SALINITY trimmer can be used to set the altitude correction value.

Enter the mg/L mode.

Press the SALINITY g/L button. Turn the SALINITY trimmer to display the salinity value corresponding to the desired altitude.

See below table for reference:

ALTITUDE	g/L	ALTITUDE	g/L
250 m	6	1250 m	26
500 m	11	1500 m	31
750 m	17	1750 m	36
1000 m	22	2000 m	40

ALARM

Press the "ΔALARM" key and the display will show the set tolerance for the alarm.

Use a small screwdriver to adjust the "ΔALARM" trimmer until the desired tolerance is displayed.

For example, if the set value is 10 mg/L and a ΔAlarm of 2 mg/L is set, an alarm will be activated every time the measured value is lower than 8 mg/L.

When an alarm occurs, the "ALARM" LED lights up.

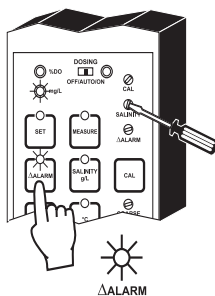

The alarm contacts of **HI 8410** remain closed during normal operation. If the measured conductivity level is not within the tolerance of the set value, the alarm contact will be open.

HYSTERESIS SET

Turn the hysteresis knob (rear panel) in the desired position (from 0.5 to 2.4 mg/L range).

The dosage will be active according to the DO reading set point value and hysteresis set value.

TAKING MEASUREMENTS WITH HI 8410

After selecting the range (mg/L or % DO), setting the working point, hysteresis, salinity factor and alarm value, press the "MEASURE" key. The DO value of the test solution will be displayed.

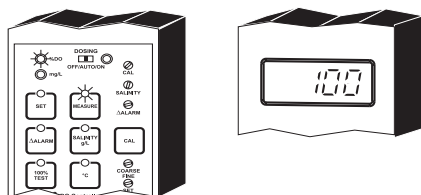

If the reading is out of range the instrument displays:



TEMPERATURE MEASUREMENT

Press and hold the "°C" key and the display should indicate the temperature of the tested solution.

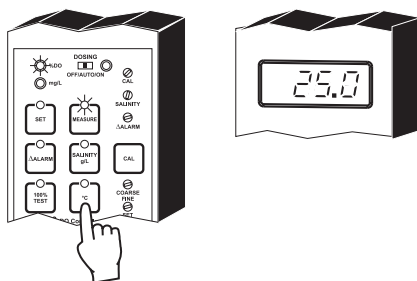

CALIBRATION PROCEDURE

Calibration is a very simple 1-point procedure, performed in air, only in % DO range.

Ensure the probe is ready for measurements, i.e. the membrane is filled with electrolyte (see "Probe Preparation" section for details).

If the instrument is set on the % DO range (the mg/L range selection switch on the rear panel is open) simply turn the CAL trimmer to display 100%. If the instrument is set on the mg/L range press and hold down the CAL key to enter % DO range and turn the CAL trimmer to display 100%. After CAL key is released the instrument returns to mg/L range.

If the environmental relative humidity is lower than 30%, pour some deionized water (approx. 3 mm) in the white cap supplied with the membrane. Insert the probe in the cap and calibrate.

Keep the probe in vertical position to avoid any contact of the membrane with the water.

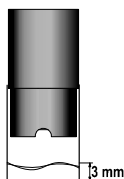

Note: For best accuracy, calibration should be performed on the measurement site, and the probe should be at the same temperature as the air.

Note: After replacing the membrane or the electrolyte solution, wait a few minutes for the reading to stabilize.

DIAGNOSTIC TESTS

The HI 8410 controllers are designed with built-in diagnostic functions to enable the user to check and troubleshoot the instrument. The checks performed are through the front panel keys and can be used to isolate the cause of malfunction.

Press the "MEASURE" key before proceeding with the following tests.

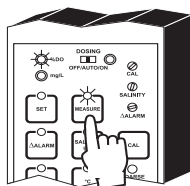

100% Test

Press and hold the CAL key and then press the 100% TEST key, the display should indicate a value in the interval between 30% and 200% DO.

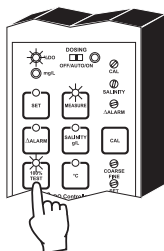

LED INDICATION

All LEDs above the keys or near switches indicate the state of each function, whether it is active or the display is indicating the mode.

- % DO LED** It is on if the selected range is % DO.
- mg/L LED** It is on if the selected range is mg/L.
- OFF/AUTO/ON LED** It is on when the switch is in OFF (dosage disabled) or in ON (dosage continuous enabled) position.
- SET LED** In MEASURE mode it is OFF or blinking (25% ON) in accordance with the dosage relay status (inactive/active).
In SET mode it is ON or blinking (75% ON) in accordance with the dosage relay status (inactive/active).
- △ALARM LED** In MEASURE mode it is OFF or blinking (25% ON) in accordance with the alarm status (inactive/active).
In △ALARM set mode it is ON or blinking (75% ON) in accordance with the alarm status (inactive/active).
- MEASURE LED** It is ON while the instrument is in MEASURE mode.
- SALINITY g/L LED** It is ON while the instrument is in SALINITY set mode.
- 100% TEST LED** It is ON when the 100% TEST key is pressed.
- °C LED** It is on when the °C key is pressed and the temperature is displayed.

PROBE MAINTENANCE & CLEANING

For a top performance probe, it is recommended to replace the membrane every 2 months and the electrolyte once a month.

Proceed as follows:

- Unscrew the membrane by turning it counterclockwise.
- Rinse the supplied spare membrane (**HI 76409A/P**) with some electrolyte solution while shaking it gently. Refill with clean electrolyte.
- Gently tap the membrane over a surface to ensure that no air bubbles remain trapped.
- With the sensor facing down screw the cap clockwise to the end of the threads. Some electrolyte will overflow.

If any deposit scales the sensors, gently brush the sensor surface with the supplied scouring pad, while paying attention to not damage the plastic body.

ACCESSORIES

- HI 76409/4** Galvanic DO probe with built-in temperature sensor and 4 m cable
- HI 76409/10** Galvanic DO probe with built-in temperature sensor and 10 m cable
- HI 76410-0** Protective sleeve for **HI 76410** probes series
- HI 76410A/P** Membrane for **HI 76410** probes series, 5 pcs.
- HI 7042S** Electrolyte solution, 30 ml bottle
- HI 710015** Shockproof rubber boot, blue color
- HI 710016** Shockproof rubber boot, orange color
- HI 731326** Calibration screwdriver (20 pcs)

Hanna Instruments reserves the right to modify the design, construction and appearance of its products without advance notice.

WARRANTY

All HANNA instruments® meters are warranted for two years against defects in workmanship and materials when used for their intended purpose and maintained according to instructions.

The probes are warranted for a period of one year.

This warranty is limited to repair or replacement free of charge.

Damages due to accident, misuse, tampering or lack of prescribed maintenance are not covered.

If service is required, contact the dealer from whom you purchased the instrument. If under warranty, report the model number, date of purchase, serial number and the nature of the failure. If the repair is not covered by the warranty, you will be notified of the charges incurred.

If the instrument is to be returned to HANNA instruments®, first obtain a Returned Goods Authorization Number from the Customer Service department and then send it with shipment costs prepaid.

When shipping any instrument, make sure it is properly packaged for complete protection.

Recommendations for Users

Before using these products, make sure that they are entirely suitable for the environment in which they are used.

Operation of these instruments in residential area could cause unacceptable interferences to radio and TV equipments, requiring the operator to take all necessary steps to correct interferences.

The trimmers are sensitive to electrostatic discharges. It is recommended to use anti-static screwdrivers.

Unplug the instrument from the power supply before replacing the fuse. External cables to be connected to the rear panel should end with cable lugs.

To maintain the EMC performance of this equipment, use the proper cables.

Any variation introduced by the user to the supplied equipment may degrade the instruments' EMC performance.

To avoid electrical shock, do not use these instruments when voltages at the measurement surface exceed 24 Vac or 60 Vdc.

To avoid damages or burns, do not perform any measurement in microwave ovens.

All rights are reserved. Reproduction in whole or in part is prohibited without the written consent of the copyright owner.



Hanna Instruments Inc.
Highland Industrial Park
584 Park East Drive
Woonsocket, RI 02895 USA

Local Sales and Customer Service office

Hanna Instruments United States Inc.
Highland Industrial Park
584 Park East Drive
Woonsocket, RI 02895 USA
Tel. (800) 426 6287
Fax (401) 765 7575
www.hannainst.com/usa

Technical Support for customers
Telephone (800) 426 6287
Fax (401) 765 7575
E-mail tech@hannainst.com