

INSTRUCTION MANUAL

THERMO HYGRO-ANEMOMETER



Model: 8918

INTRODUCTION

Congratulations on your purchase of the unique 3 in one Anemo-Thermometer, the meter features dual display of Air Velocity and Temperature or Relative Humidity with Dew Point . Simple and easy to operate, 7 units to be switchable.

A pocket-knife design makes it convenient and portable , easy to use and to get a precision reading.

Read throughly before using the meter, the unit was calibrated before shipment . There are several models of mini-anemometer and weather meter available ,please contact with your store for more detail information .

FEATURES/FUNCTIONS

- **Temp./Windchill** : update every second
- **Windspeed** : update every second, 5, 10, 13 second moving average are selectable.
- **Relative Humidity** : response time is 15 seconds. Update every 2 seconds.
- **Temperature sensor** : Sealed precision thermister.
- **Humidity sensor** : Capacitor sensor.
- **Water resistant** shock proof to 1 M .
- **Data hold** by one button operation.
- **Records** Maximum reading.
- **Unit** °C/°F switchable.

- **Safety lanyard** makes it carry around and avoids falling over.
- **Material supplied** : Meter, Battery **CR2032**, safety lanyard and manual.

RANGE / RESOLUTION

"RS" stands for Resolution.

Unit		Range	RS
MS	Meter per second	1.1~20.0	0.1
FPM	Feet per minute	60~3937	2
KNT	Knot	0.4~38.8	0.1
KMH	Kilometer per hour	0.8~72.0	0.1
MPH	Mile per hour	0.5~44.7	0.1
BF	Beaufort	1~8	1
RH%	Relative Humidity	5~95	0.1
DP	Dew Point	0~50	0.1
°C	Centigrade	-18~50	0.1
°F	Fahrenheit	0~122	0.1

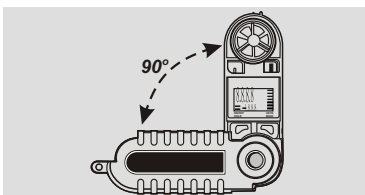

☛ Detented at 90° for tripod mountable.

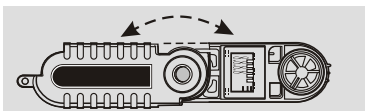

☛ Detented at 180° for fully opened.

DESCRIPTION

1. Vane impeller
2. Precision thermister
3. LCD display
4. **ON/OFF** and **HOLD** key
5. **UNITS** and **MODE** key
6. Battery compartment (on rear)
7. Swivel handle and storage case
8. Lanyard holder
9. Humidity sensor
10. Tripod mount (on the bottom)

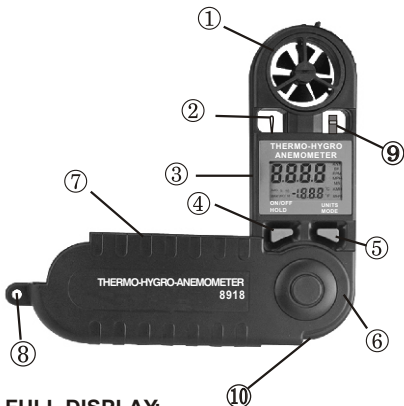

FULL DISPLAY:

Though you have seen HI (Heat Index) , it is an optional feature on new model 8909/8910.



POWER ON / OFF

To monitor the air velocity measurement , always position the meter to the air source from the rear of the meter .i.e. the display face to the user .

By pressing the **ON/OFF/HOLD** key momentarily. The Dual Display will illuminate. The top (larger) display indicates air speed and the lower display indicates temperature.(See Fig. 1)

Press and hold **ON/OFF/HOLD** key for approx. 3 seconds to turn the meter off . The meter will also power off after 20 minutes of inactivity .

↑ *Fig.1*



SELECT AIR VELOCITY UNITS

When normal mode , the LCD shows temperature units (°C or °F) and Air Velocity units. **Note:** The meter defaults unit **KNT °F** (See Fig.2).

If you want to change the air velocity unit , simply press the **UNITS/MODE** key and **ON/OFF HOLD** key simultaneously , until the display is turns on , while the display is blinking , release only **ON/OFF HOLD** key , and repeatedly press the **UNITS/MODE** until the desired units are displaying.

The unit cycles through **KNT** , **BF** , **FPM** , **MPH** , **MS** , **KMH** (See Fig. 3, 4, 5 for examples) and then back to the normal display in 5 seconds .



⬆ Fig.2



⬆ Fig.3



⬆ Fig.4



⬆ Fig.5

**CHANGE THE LOWER
DISPLAY PARAMETER**

If want to change display parameter:
When the meter is on, press and hold **ON/OFF/HOLD**, meantime press the **UNITS/MODE** key repeatedly to select through Temperature (°F/°C), Humidity (%RH), Dew Point (TD) and Wind Chill Temperature (WCI). The bigger character at the center display is Air Velocity, the smaller character is the value of the desired units . At the right lower section will be either °C or °F or RH% , at the left lower section will be either TD or WCI .(See Fig.6 , 6-1 ,6-2, 6-3)



⬆ Fig.6



⬆ Fig.6-1



⬆ Fig.6-2



⬆ Fig.6-3

TEMPERATURE UNIT

To select the temperature units:

Turn the meter OFF first. Press and hold down both buttons until the display turns on and begins blinking then release the buttons.

Press both buttons momentarily to change temperature unit. After 5 seconds, the meter switches back to normal operation mode automatically.

MAX. OPERATION (only for windspeed)

After a measurement session, press and hold the **UNITS/MODE** key until the **MAX** icon appears on the lower left-hand side of the LCD. (See Fig. 7). Air Velocity indication on the top display will represent the highest readings measured since the meter was last powered.



⬆ Fig.7

AVERAGE MODE (only for windspeed)

Normally the meter update windspeed readings every 1 second. You will see no icon is appeared (Fig.8) .

To select **5**, **10** or **13** seconds averaging, first press and hold the **UNITS/MODE** key until the **MAX** icon appears.(See Fig.7).

Next, press the key again momentarily and the icon will appear with **AVG** icon, it stands for the 13 second average mode now is selected. (See Fig.8-1). The lower icon cycles through **MAX**, **AVG(13)**, **5**, **10** , no icon .



⬆ Fig.8



⬆ Fig.8-1

Now press the key once more for a 5 second average mode, display shows as Fig.9.

Press one more time for a 10 second average mode , display now shows as Fig 10. To return to normal operation press the **UNITS/MODE** key repeatedly until all lower left-hand icons disappear.



⬆ Fig.9



⬆ Fig.10

DATA HOLD

(To freeze the most recent display), by pressing and holding the **ON/OFF/HOLD** key while taking measurements. To return to normal operation release the key and restart the meter.

WIND CHILL INDICATOR

When power is on , press and hold **ON/OFF/HOLD** button, then press **UNITS/MODE** keys to select from $^{\circ}\text{C}$ or $^{\circ}\text{F}$, **RH%** , **TD** then **WCI** , when **WCI** icon appears , release **UNITS/MODE** button first , then immediately release **ON/OFF/HOLD** button . (See Fig.11) Otherwise, the meter will turn off after

3 seconds, The temperature display will now factor in the wind chill.



↑ Fig.11



↑ Fig.12

To return to the normal mode , follow the same step as above, press **ON/OFF/HOLD** and **UNITS/MODE** simultaneously and momentarily press **UNITS/MODE** button to escape **WCI** (Windchill) and **TD** (Dew Point) features.

NOTE:

When it is in the normal mode with **WCI** or **TD** function , if you keep pressing **UNITS /MODE** button , you will see either

MAX or **AVG** or **5** or **10** appears at the lower corner , **IT DOESN'T STAND FOR ANY** . As those maximum or average recalling for only Wind Speed .(See Fig.12)

UNITS CONVERSION TABLE

	1 MS	1 FPM	1 KNT	1 KMH	1 MPH
MS	1	0.00508	0.5144	0.2778	0.4464
FPM	196.87	1	101.27	54.69	87.89
KNT	1.944	0.00987	1	0.54	0.8679
KMH	3.6	0.01829	1.8519	1	1.6071
MPH	2.24	0.01138	1.1523	0.6222	1

BATTERY REPLACEMENT

If the meter will not power up as usual or the display contrast becomes weak and difficult to read, replace the lithium battery. To do so , turn the battery compartment cover in a **CLOCKWISE** direction to remove it. (See Fig.13)

The battery will be visible in the battery compartment, observe the position of the battery and replace the new one in the same position. Affix the battery compartment cover by turning it in a **COUNTER-CLOCKWISE** direction.

Dispose of the lithium battery in accordance with local, state, or national waste disposal codes.

WARNING :

Ensure you have turn off the meter before opening the battery compartment.

➔ **Fig.13**



VANE REPLACEMENT

NOTE: The anemometer is very accurate at low and mid-range air speeds. Constant use at very high speeds, such as measurements out a fast-moving car window may damage the impeller's bearing and reduce over-all accuracy.

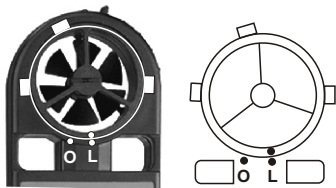

↑ **Fig.14**

To replace the impeller, use a small screwdriver to loosen the set-screw found on the back of the windmeter. The remove the impeller by twisting the impeller assembly clockwise (if you are facing the back of the windmeter) to the "O" position marked on the rear of the rear of the meter. (See Fig.14)

Install a new impeller by following these instructions in reverse.

SPECIFICATION

Min/Max.Windspeed	0.5~44.7 MPH
Min/Max.Windspeed	60~3937 FTM
Average readings	5/10/13 second
Dimension	(180° fully opened) 235 x 45 x 25mm
Dimension	(90° folded) 140 x 45 x 25mm
Impeller Dia.	33 x 16 mm (T)
Unit in Imperial	°F ,FTM ,MPH
Unit in Metric	°C ,MS ,KMH
Unit	KNT, BF
Operating Temperature	-15°C~50°C
Response time :	
Wind Speed	1 second
Temperature	1 minute
Relative Humidity	15 seconds
Accuracy:	
Wind Speed	± 4% (See below)
Temperature	± 1°C or ± 1.8°F
Relative Humidity	± 3% (5~95%RH)
Dew Point	± 2°C or ± 3.6°F
WindChill	± 3% F.S
Beaufort	± 4% (See below)

The windspeed accuracy is $\pm 4\%$ or \pm last significant digit, whichever is greater. The sample time for air velocity and temperature is a reading per second ,but 1 reading per 15 seconds for humidity with 2 seconds updates .

WARRANTY

The meter is warranted to be free from defects in material and workmanship for a period of one years from the date of purchase.

This warranty covers normal operation and does not cover batteries, misuse, abuse, alteration, tampering, neglect, improper maintenance, or damage resulting from leaking batteries. Proof of purchase is required for warranty repairs.

RETURN AUTHORIZATION

Authorization must be obtained from the supplier before returning items for any reason. When requiring a RA (Return Authorization), please include data regarding the defective reason, the meters are to be returned along with good packing to prevent any damage in shipment and insured against possible damage or loss .

CE CERTIFICATION

The meter conforms to the following standards:

* **EN 50081-1/1992** : EN 55022

* **EN 50082-1/1997** : EN 55024

(EN 61000-4-2/-3/-8, ENV 50204)

, the meter complies with the essential protection requirements of Council Directive 89/336/EEC on the approximation of the laws of the Member States relating to electromagnetic compatibility.

**Accuracy, the Zenith of
Measuring / Testing Instruments !**

Hygrometer/Psychrometer

Thermometer

Anemometer

Sound Level Meter

Air Flow meter

Infrared Thermometer

K type Thermometer

K.J.T. type Thermometer

K.J.T.R.S.E. type Thermometer

pH Meter

Conductivity Meter

T.D.S. Meter

D.O. Meter

Saccharimeter

Manometer

Tacho Meter

Lux / Light Meter

Moisture Meter

Data logger

Temp./RH transmitter

Wireless Transmitter

More products available !

www.ponpe.com

2008.06rev